

SELF-ACTUATING RELIEF PRESSURE REGULATORS TYPE ZSN3

APPLICATION AREA:

Regulators ZSN3 are used to control preset pressure in process installations connected to regulator valve inlet. Regulators are applied in heating systems, in industrial processes with cold and hot water, steam, air and non-flammable gases. Using with other media subject to consulting with manufacturer.

DESIGN:

Regulator comprises three, temporary fastened main units: valve (01), actuator (02) and adjuster (03). Regulator valve single-ported with balanced plug. Flanged connections of valve body with valve face as per PN-EN 1092-1:2006 and PN-EN 1092-2:1999 for PN10; 16; 25; 40 PN-EN 1759-1:2005 for CL150; CL300.

Body length as per:

PN-EN 60534-3-1:2000 – Series 1 for PN10; 16; 25; 40;

Series 37 for CL150; Series 38 for CL300

Valve tightness – bubble (Class VI as per PN-EN 60534-4), tight seat in PTFE or VMQ (ECOSIL).

Diaphragm actuator (diaphragm effective area 80 cm²), with clammed housing or diaphragm actuator (diaphragm effective area 160 cm²), with bolted housing.

Control pressure value adjuster with combination of three pre-tensioned springs, fixed coaxially with valve and actuator.

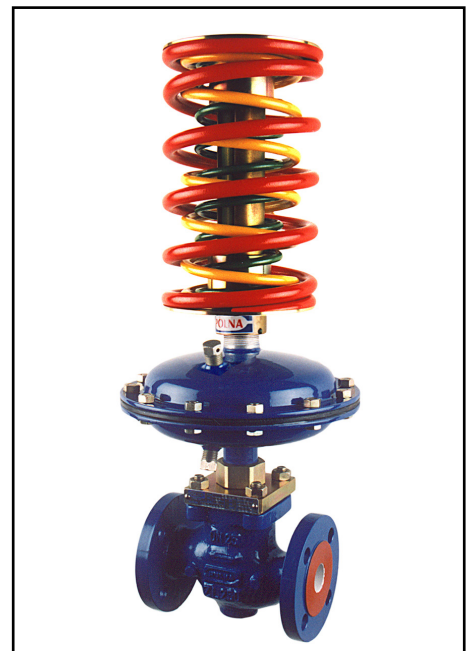

VARIANTS:

By corrosion-proofness of actuator components:

- standard (ZSN 3.1) - carbon steel with protection coatings,
- special (ZSN 3.2) - stainless steel.

OPERATING PRINCIPLE:

Valve is closed when no supply. Controlled pressure is fed via impulse duct through connection (24) under diaphragm (29) of actuator (02). Actuator second chamber is connected to atmosphere via deaeration plug (25). Increase in control pressure above preset value, set by tensioning of spring unit (60) in adjuster (03), causes deflection of diaphragm, movement of actuator stem (37) and opening of valve plug (5) until controlled pressure reaches value preset in booster.

Impulse collection point for controlled pressure is to be located upstream valve inlet.

DIMENSIONS AND WEIGHTS

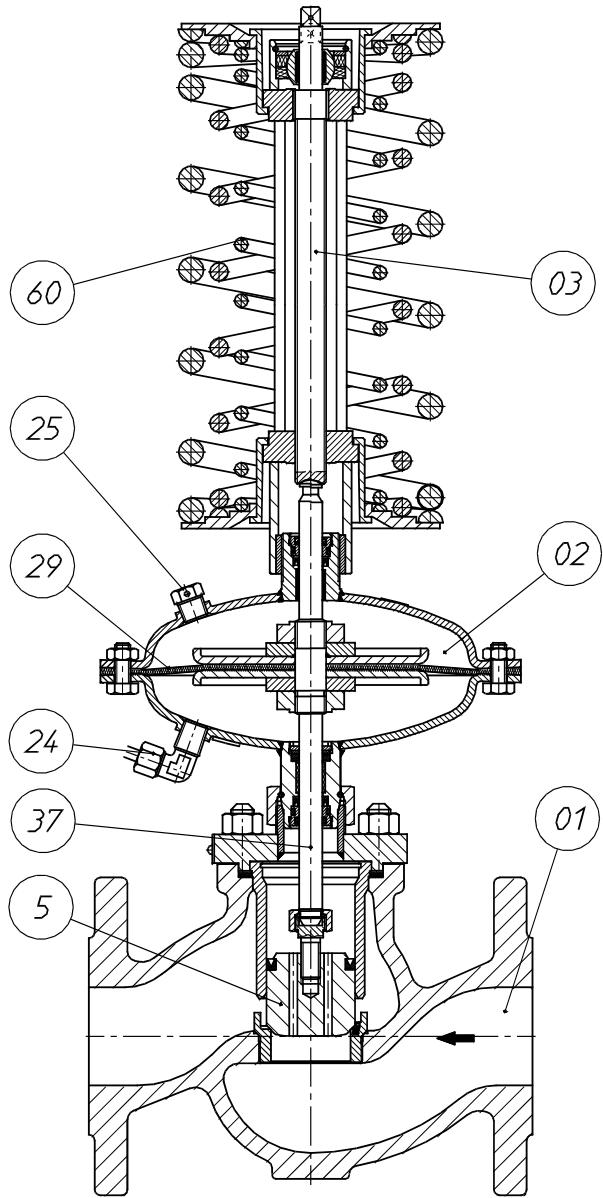
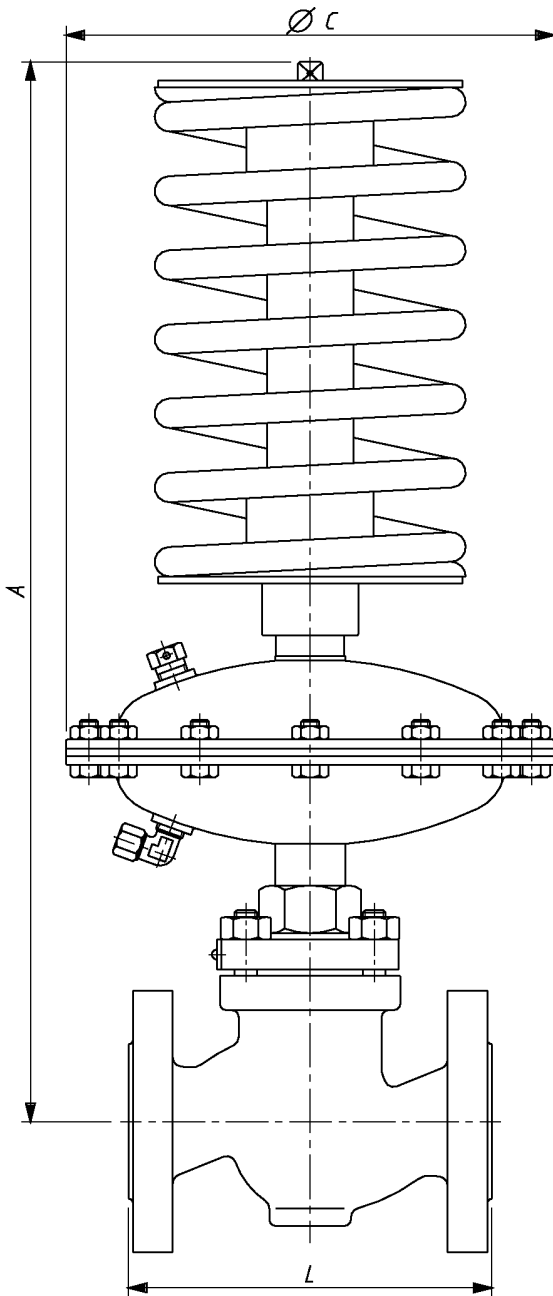

DIMENSIONS AND WEIGHTS

DN	A	L	Valve weight (01)
	[mm]		[kg]
15	470	130	4,0
20		150	5,1
25		160	5,6
32	485	180	8,5
40	490	200	10,6
50	495	230	14
65	605	290	23
80		310	29
100	615	350	44
125	special execution, technical data according to individual inquiries		
150			

Spring range [kPa]	C [mm]	Diaphragm effective area [cm ²]	Weight		
			Actuator (02)	Adjuster (03)	
				DN 15...50	DN 65...100
40...160	215	160	4,4	3,2	3,6
100...400				5,6	7,1
200...800	150	80	2,4	6,8	8,5
280...1120					
other spring ranges available on request					

TECHNICAL SPECIFICATIONS

DN		15	20	25	32	40	50	65	80	100	125	150		
K _{vs} ¹⁾ [m ³ /h]	full flow	3,2	5	8	12,5	20	32	50	80	125	special execution, technical data according to individual inquiries			
	reduced flow	1	1,6	2,5	5	8	12,5	20	32	50				
		1,6	2,5	3,2	5	8	12,5	20	32	50				
Stroke [mm]		6			8			12		14				
Noise coefficient Z		0,65	0,6	0,55		0,45	0,4		0,35					
Control characteristics		proportional												
Spring range [kPa] ²⁾		40...160;			100...400;			200...800;		280...1120				
Maximum pressure in actuator chamber [bar]		20												
Allowed pressure drop in valve [bar]		12						10						
Valve nominal pressure		valve body in grey iron							PN 16					
		valve body in spheroidal iron							PN 16; PN 25; PN 40					
		valve body in carbon steel and stainless steel							PN 16; PN 25; PN 40					
Maximum medium temperature [°C]		water												
		steam												
		gases												

¹⁾ other flow ratios K_{vs} subject to order specification.

²⁾ other ranges subject to order specification.

MATERIALS as per PN

Regulator	ZSN 3.1	ZSN 3.2
VALVE (01)		
Body	grey iron EN-GJL-250 spheroidal iron EN-GJS-400-178LT carbon steel GP240GH (1.0619) stainless steel GX5CrNiMo 19-11-2 (1.4408)	
Plug and seat	X6CrNiMoTi 17-12-2 (1.4571)	
Guide sleeve		
Packing	EPDM ³⁾	
ACTUATOR (02)		
Housing	carbon steel S235JRG2C (1.0122)	stainless steel X6CrNiTi 18-10 (1.4541)
Stem	X17CrNi 16-2 (1.4057)	
Diaphragm	EPDM + polyester fabric ³⁾	
Packing	EPDM ³⁾	
Adjuster (03)		
Adjuster components	carbon steel C45 (1.0503)	
Springs	spring steel 60Si7	

³⁾ other materials, subject to medium type.

NOMINAL PRESSURE, WORKING TEMPERATURE AND WORKING PRESSURE

Material: EN-GJL 250 as per PN-EN 1561					
PN	Standard	Temperature [°C]			
		-10...120	150	180	200
Allowable working pressure [bar]					
PN10	PN-EN 1092-2	10	9	8,4	8
PN16		16	14,4	13,4	12,8

Material: EN-GJS 400-18 LT as per PN-EN 1563					
PN	Standard	Temperature [°C]			
		-10...120	150	200	
Allowable working pressure [bar]					
PN10	PN-EN 1092-2	10	9,7	9,2	
PN16		16	15,5	14,7	
PN25		25	24,3	23	
PN40		40	38,8	36,8	

Material: GP240GH (1.0619) as per PN-EN 10213-2					
PN	Standard	Temperature [°C]			
		-10...50	100	150	200
Allowable working pressure [bar]					
PN10	EN 1092-1 ⁴⁾	10	9,2	8,8	8,3
PN16		16	14,8	14	13,3
PN25		25	23,2	22	20,8
PN40		40	37,1	35,2	33,3

Material: GX5CrNiMo 19-11-2 (1.4408) as per PN-EN 10213-4					
PN	Standard	Temperature [°C]			
		-10...50	100	150	200
Allowable working pressure [bar]					
PN10	EN 1092-1 ⁴⁾	10	10	9	8,4
PN16		16	16	14,5	13,4
PN25		25	25	22,7	21
PN40		40	40	36,3	33,7

⁴⁾ other standards on request

INSTALLATION

Regulator is to be installed on horizontal pipeline. Medium flow direction is to conform to arrow on body. At medium temperature lower than 130°C regulator position is optional, at higher temperatures it is recommended to install regulator with adjuster unit (03) down. To ensure reliable operation of regulator apply strainer FS1 upstream and needle valve ZWD 1 at impulse collection point. When applying regulator for steam installation of condensation tank is recommended.

EXAMPLES OF APPLICATION

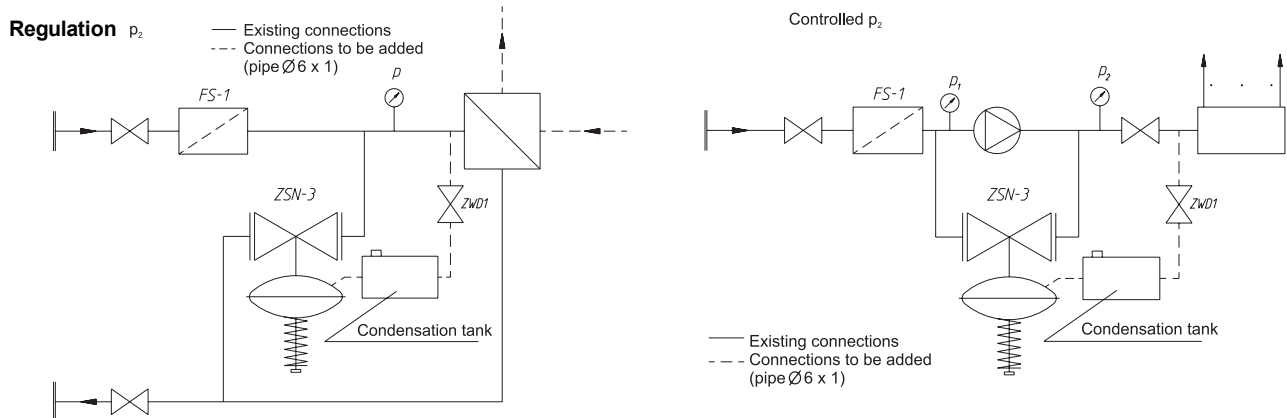

ACCESSORIES

Delivered:

- nut and cutting ring for impulse tube,

Optional (ordered separately):

- strainer FS1,
- straight tube connection $\varnothing 6 \times 1$,
- connection stub NPT 1/4"
- impulse tube $\varnothing 6 \times 1$,
- adjustment wrench,
- condensation tank,
- needle valve ZWD 1.

ORDERING

In your order specify regulator type and marking, ZSN 3.1 or ZSN 3.2, DN nominal diameter, PN nominal pressure, flow ratio K_{vs} , body material, spring range.

Example of order:

ZSN 3.1 – DN 32; PN 16; Kvs 8; spheroidal iron; 200...800 kPa.