

STEAM DESUPERHEATERS: RING TYPE SP-1, LANCE AND PISTON TYPE ST-1

SP-1 TYPE RING STEAM DESUPERHEATER

APPLICATION:

For the diameters of steam pipelines up to DN150

FEATURES:

- compact structure for installation between flanges
- lack of movable parts
- scope of adjustment up to max Kvs 1.0
- adjustment 3:1 of control efficiency for cooling water pressure

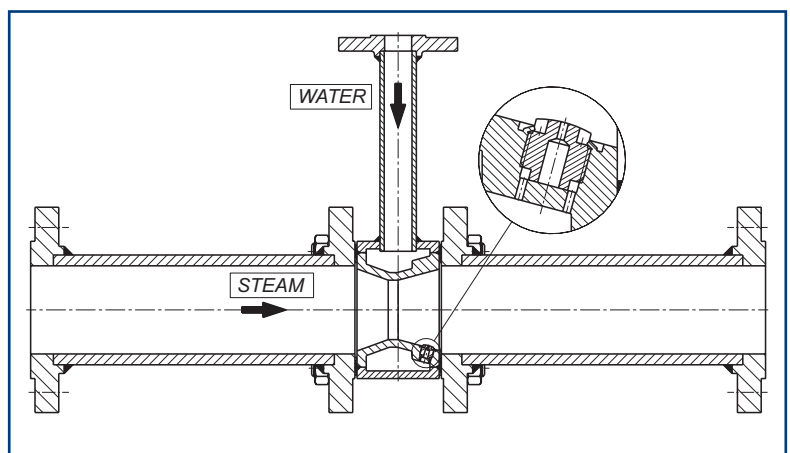

PRINCIPLE OF OPERATION:

The cooling water is supplied to the injection nozzle(s) through the feeding flange stub pipe or with a welded connection. The amount of cooling water supplied to the steam pipeline is adjusted by changing its pressure at the inlet to the desuperheater.

DESIGN

diameter of the steam pipeline:

DN32 ... DN150 , PN16, 25, 40, 63, 100

diameter of the cooling water pipeline:

DN25/ 40/ 50; PN40; 63; 100; 160

Other DN / PN values, as well as the flange connections as per the ANSI norms - upon request.

Nozzles:

with empty or full spray cone, degree 60...90°.

Materials:

- body:

S355J2G3 ; (1.0570); 13CrMo 4-5 ; (1.7335)

- nozzles:

X6CrNiMoTi 17-12-2 ; (1.4571)

Other materials - upon request.

ST-1 TYPE LANCE STEAM DESUPERHEATER

APPLICATION:

For the diameters of steam pipelines over DN150.

FEATURES:

- structure for flange installation on the lateral stub pipe of the cooling chamber
- lack of movable parts
- scope of adjustment up to max Kvs 1.0
- adjustment 3:1 of control efficiency for cooling water pressure

PRINCIPLE OF OPERATION:

The cooling water is supplied to the injection nozzle(s) through the feeding flange stub pipe or with a welded connection. The amount of cooling water supplied to the steam pipeline is adjusted by changing its pressure at the inlet to the desuperheater.

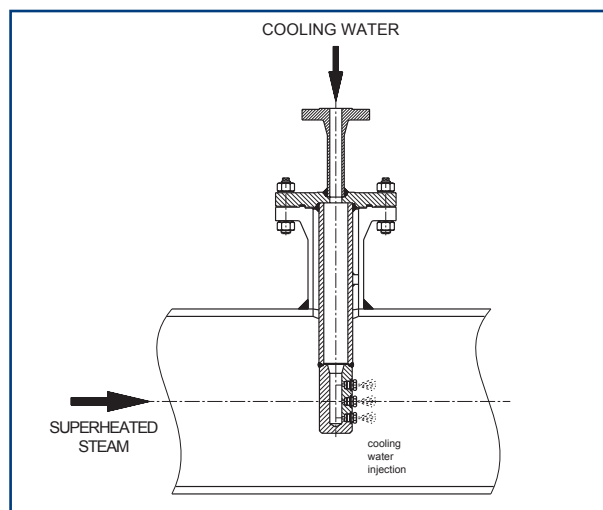
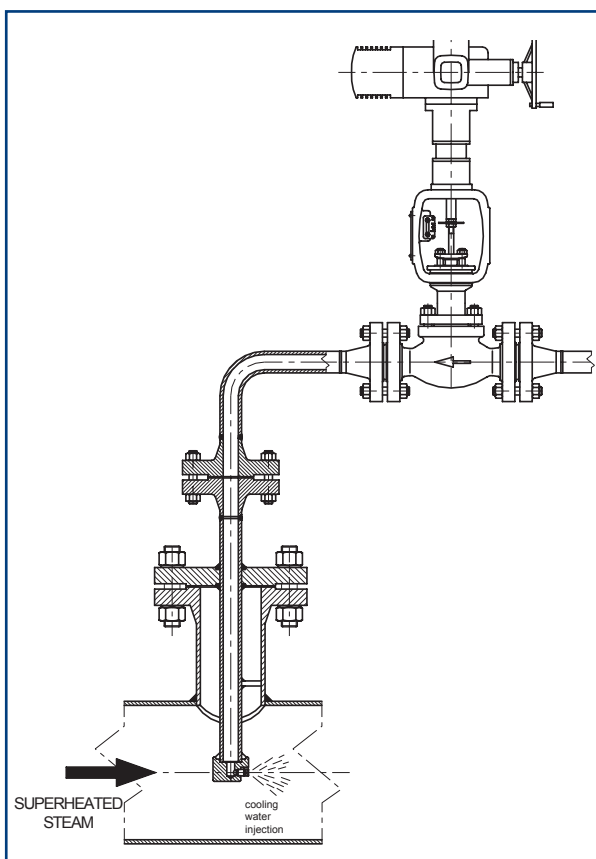

DESIGN

diameter of the steam pipeline:

od DN100, PN16, 25, 40, 63, 100

diameter of the cooling water pipeline:

DN25/ 40/ 50; PN40; 63; 100; 160

Other DN / PN values, as well as the flange connections as per the ANSI norms - upon request.

Nozzles:

with empty or full spray cone, degree 60...90°.

Materials:

- body:

S355J2G3 ; (1.0570); 13CrMo 4-5 ; (1.7335)

- nozzles:

X6CrNiMoTi 17-12-2 ; (1.4571)

Other materials - upon request.

ST-1 TYPE PISTON DESUPERHEATER

APPLICATION:

It is applied in the system of regulating the steam temperature in the industry and energy sectors. The task of the desuperheater is to provide the injection of water with perfect atomization to the pipeline of superheated steam for the purpose of cooling it to the set parameters.

FEATURES:

- possibility to produce the desuperheaters with the flow coefficients consistent with the clients' request,
- resistance to depressurization as a result of using the spiral, elastic metal-graphite gasket on the stub pipe,
- wide range of flange connections,
- possibility to adapt the materials to client's requirements,
- easy replacement of the socket and internal elements of the desuperheater,
- possibility to apply one type of pneumatic membrane actuator within the scope of strokes up to 100 mm,
- possibility to apply other drives at the client's request: pneumatic, electrical, hydraulic.



PRINCIPLE OF OPERATION:

The cooling water is delivered from a lateral connector to the inside of the desuperheater after opening the seat. The head is equipped with a set of independent nozzles with the full spray cone of 90°. Inside the head there is a piston sealed with steel elastic rings. The movement of the piston causes the flow of water to the next nozzles, thus providing the linear characteristics of the flow (or close to stable percentage characteristics). The amount and efficiency of the nozzles and the stroke of the piston are adapted to the required flow coefficient. Both the head and the nozzles are secured against unscrewing with the use of the deformation of the plastic security ring. The desuperheater has divided structure, which allows to easily replace the sockets and internal elements.

DESIGN

Flange connectors:

- water: DN25/ 40/ 50; PN40; 63; 100; 160
- steam: DN80/ 100/ 150; PN25; 40; 63; 100

Other DN / PN values, as well as the flange connections as per the ANSI norms - upon request.

Nozzles:

- with empty or full spray cone, degree 60...90°.

Materials:

- body, bonnet: S355J2G3 ; (1.0570); 13CrMo 4-5 ; (1.7335)
 - head, internal elements: X17CrNi 16-2 ; (1.4057)
 - nozzles: X6CrNiMoTi 17-12-2 ; (1.4571)
- Other materials - upon request.

Flow coefficients:

Kv 0,15...10

Leakage class:

class V acc. to PN-EN 60534-4

Rangeability:

40:1

Drive:

Membrane, spring pneumatic actuator of the P4 type, membrane active surface 240cm², maximum stroke - 100 mm, feeding pressure - 400 kPa, spring range 160 ... 320 kPa.
Other actuators - upon request

Table 1. Relationship between the stroke to Kvs and diameters of the steam connector.

Steam connector DN	Kv	Stroke [mm]
80	0,15...1,0	60
100	1,0...2,5	
150	2,5...5	80
	5...10	100

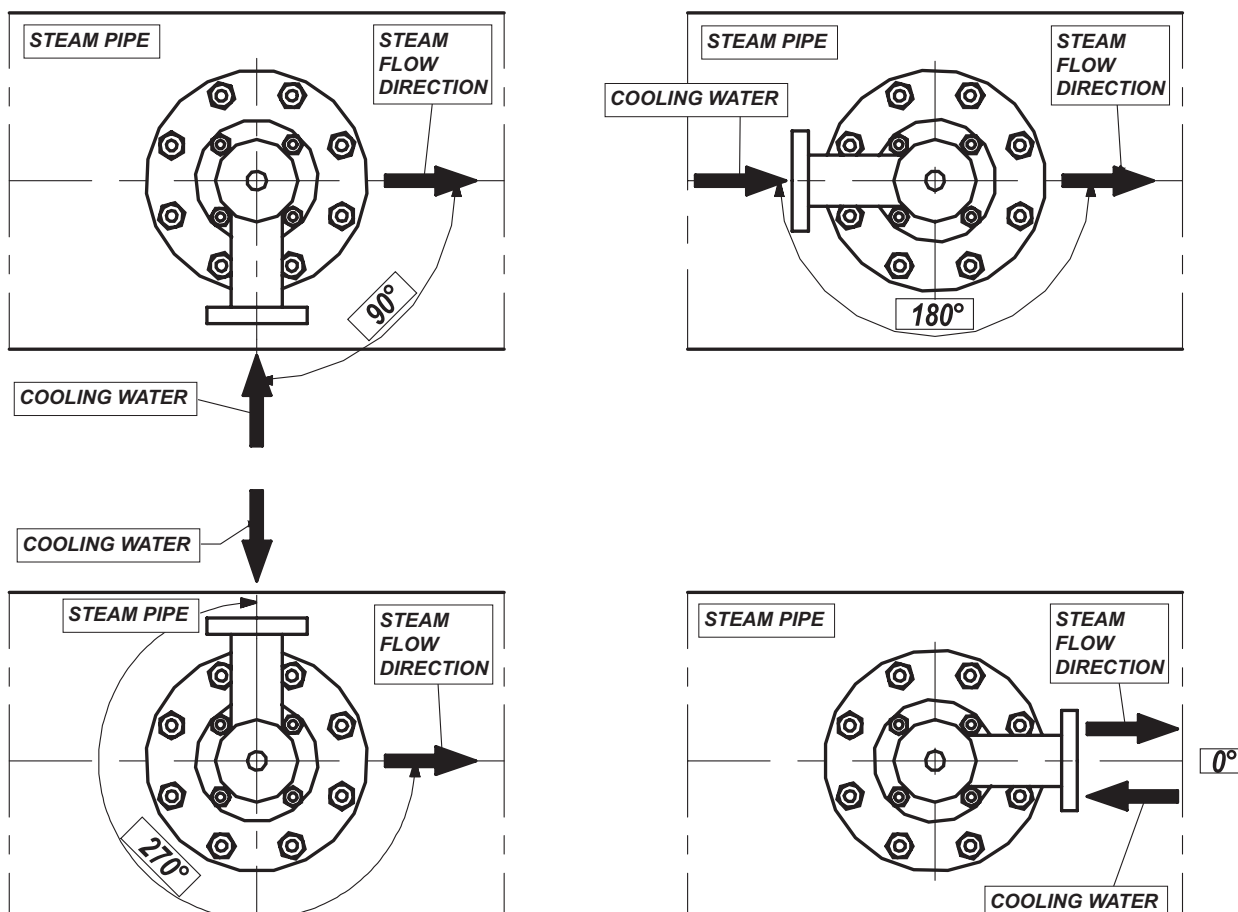

Fig. 1. Variants of location of the connector of the water flange relative to the steam flow direction.

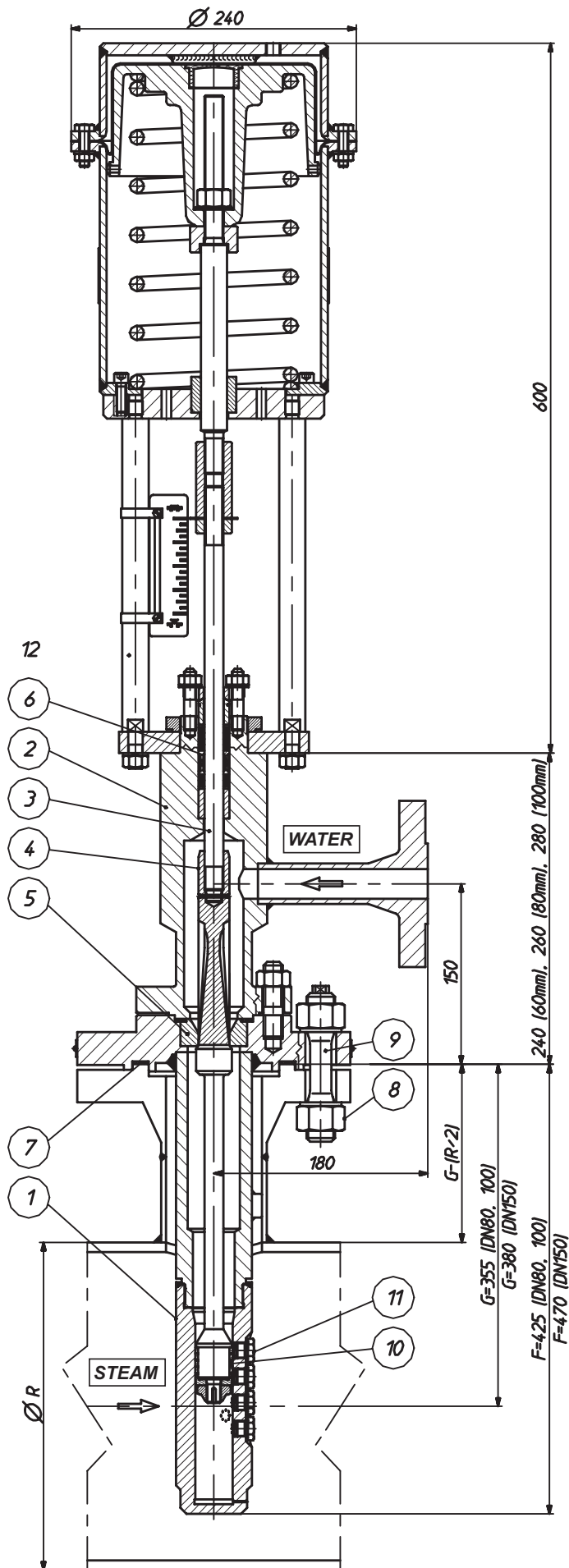

Fig. 2. Structure of the desuperheater and dimensional outline (other dimensions upon client's request).

Table 2. List of parts.

L.p.	Part name
1.	Head
2.	Bonnet
3.	Pin
4.	Piston
5.	Seat
6.	Sealing set
7.	Spiral gasket
8.	Nut
9.	Screw
10.	Ring
11.	Nozzles
12.	P4 type actuator

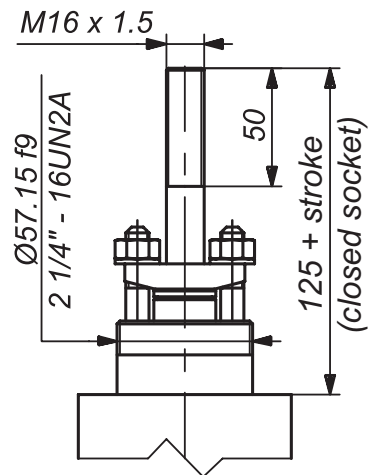
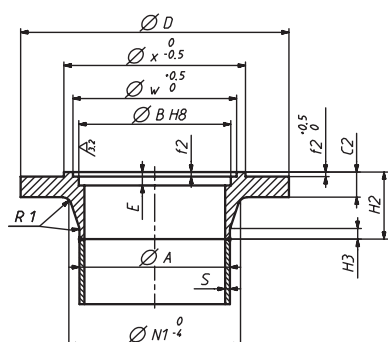

Fig. 3. Connection dimensions of desuperheater (other dimensions upon client's request).

Table 3. Dimensions of the steam counterflange.



DN	PN	A	s [min.]	D	x	w	B	E	f2	C2	H2	H3	R1	N1	K	n	L
80	25; 40	88,9	3,2	200	131,5	-	110	10	4,5	24	58	8	8	105	160	8	18
	63		3,6	215	136,5					28	72			112	170		22
	100		4,0	230	32					78	120			180	26		
100	25; 40	114,3	3,6	235	149	129	120	5	5	24	65	12	10	134	190	8	22
	63		4,0	250						30	78			138	200		26
	100		5,0	265						36	90			150	210		30
150	25; 40	168,3	4,5	300	203	183	170	15	5	28	75	10	10	192	250	12	26
	63		5,6	345						36	95			202	280		33
	100		7,1	355						44	115			210	290		33

It is possible for the Zakłady Automatyki „POLNA” SA to produce the desuperheater connector upon client’s request.

If the client produces such a connector on its own, please specify the diameter and the thickness of the pipe.

The connection dimensions of the connector are cooled as per the PN-EN 1092-1: 2010 norm for the (C) type of the flange. The sealing is standard for the (C/D) type flange connection. It is recommended to use an elastic spiral wound gasket made of the X6CrNiMoTi 17-12-2 ; (1.4571) material + GRAPHITE.

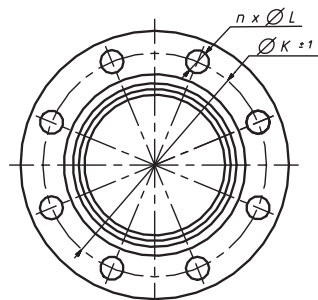
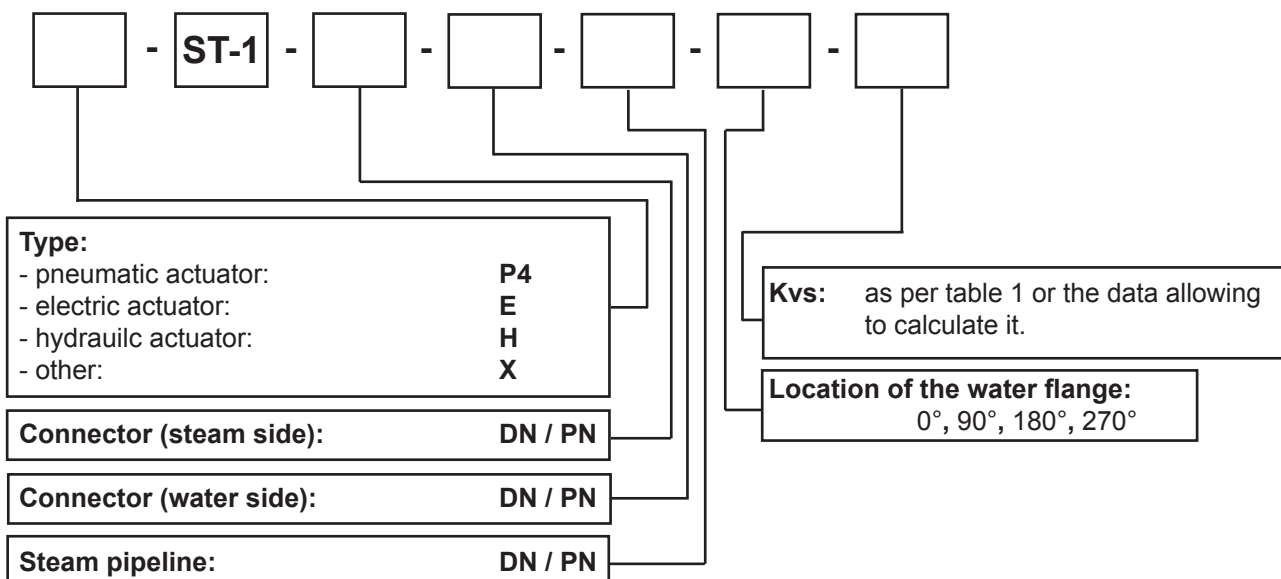

Fig. 4. Dimensions of the steam connector.

Table 4. Dimensions of the gasket.

DN	Dimensions of the flange gasket
80	131 x 111 x 3,2 (PN25; 40)
	135 x 111 x 3,2 (PN63; 100)
100	148 x 130 x 3,2
150	202 x 184 x 3,2

MARKING OF THE PISTON DESUPERHEATER:



EXAMPLE DESIGNATION: Pneumatic actuator, size - 240cm², stroke 60 mm, control pressure range 160...320 kPa, steam connector DN80 PN 63, water connector DN25 PN40, steam pipeline DN600 PN40, location of the water connector 270°, Kvs 1, linear characteristics:

P4 - ST-1 - DN80/PN63 - DN25/PN40 - DN600/PN40 - 270° - Kvs 1L

ORDERING (lance and ring desuperheaters): Before ordering the lance and ring desuperheaters, contact the Marketing and Sales Department.

ORDERING (only piston desuperheaters):

When ordering please state the marking of the drive as per the producer’s catalogue cards, the marking of the desuperheater and its operation parameters: the pressure and temperature of the flowing medium.

Apart from the a/m data, the following information is stated on the rating plate of the desuperheater:

- max working temperature [TS],
- max. working pressure [PS]
- test pressure [PT]
- liquid group [2],
- serial number and year of manufacturing.

The assistance in selecting a desuperheater is granted by: the Marketing and Sales Department and the Technology Department.