

## ROTARY PLUG CONTROL VALVES TYPE Z33®

### APPLICATION AREA:

Rotary plug control valves Z33 represent the design of valves, where change in flow ratio is achieved through eccentrically set rotary plug.

Such structures are particularly useful for control of flow under heavy-duty conditions, with high probability of cavitation and erosion.

Possibility of obtaining high flows and wide range of material and design variants make them ideal for application in many branches of industry, such as power generation, metallurgy, chemical and petroleum industry, food industry, paper industry, etc.

### FEATURES:

- one-piece valve body (cast with bonnet), no static or dynamic sealing except shaft sealing chamber,
- no "detachment effect" between plug and seat,
- ability to change  $Kv_s$  without changing plug or seat,
- easy replacement of rotary, symmetrical plug,
- elongated bonnet allows application of double sealing for shaft, meeting "low emission" standards equal to TA-LUFT conditions,
- the same  $Kv_s$  coefficients for "hard" and "soft" seats,
- leakage class less than 0.01% $Kv_s$  for "hard" seats (metal-metal),
- same flow direction for "hard" and "soft" seats,
- valve-actuator connection accessible from outside, which allows pivoting actuator to valve axis by 90° increments,
- special executions: with heat jacket, erosion-proof, for crystallizable media.



### DESIGN AND TECHNICAL SPECIFICATION:

#### Body (1)

flanged or flangeless, cast in cast steel

Nominal sizes:

DN 25; 40; 50; 80; 100; 150; 200; 250; 300

Nominal pressures:

PN10; 16; 25; 40 (as per PN-EN 1092-1:2006);

CL150; CL300 (as per PN-EN 1759-1:2005).

Steel flanges CL150; CL300 are so designed that they can be assembled with flanges executed per American standards ANSI/ASME B16.5 and MSS SP44. In American standards flanges are identified with nominal values in "Classes", to which nominal pressure (PN) values as per PN-ISO 7005-1:2002 correspond.

Equivalent identification as per PN are: CL150: PN 20 and CL300: PN 50.

Table 1. Nominal pressures and end connections

Nominal pressure	Facing of flange types			
	Raised face	Groove	Recess	Ring-joint
PN10; 16; 25; 40	B <sup>2)</sup>	D	F	-
CL150		-	-	J (RTJ)
CL300		DL (D1 <sup>1)</sup> )	F (F1)	

<sup>1)</sup> - only for CL300; <sup>2)</sup> - B1 – (Ra=12.5 mm, concentric surface structure "C"), B2 – (Ra as agreed with the customer);  
 () - identification of connections as per ASME B16.5

Possible execution of flanges per specification and indicated standards

**Z33®** is a trademark registered with Republic of Poland Patent Office.

Face-to-face dimensions:

- a) flanged valves as per PN-EN 60534-3-1:2000; Table 1, Series 1  
as per ANSI B16.10:1992; Table 1 i 2, Series 18
- b) flangeless (sandwich) as per PN-EN 60534-3-2:2002
- Bridge (2)** functions as rotary closure, cast in grey iron or steel (welded),
- Valve plug (3)** working piece in the form of globe section:
- flow characteristics: - linear (L)

- Valve seat (4)** loosely resting in body opening; susceptible to fitting to spherical cap of valve plug
- hard
  - soft (with PTFE sealing)

Leakage class:

- basic: class IV as per PN-EN 60534-4 - metallic seat
- bubble-tight: class VI as per PN-EN 60534-4 - soft seat

**Screw plug (5)** fixing seat to body (medium flow direction „under plug”); in special executions its function is preventing erosion (medium flow direction „above plug”)

**Shaft (6)** transmits torque from actuator to valve plug: burnished, with polished sealing interface.

**Guiding sleeves of plug (7) and shaft (8)** - function as slide bearings; surface hardened (CrN coating) or PTFE coated

**Packing (9)** -packing kits formed in various materials (PTFE-V; PTFE+graphite; braided or expanded graphite); special “low emission” kit, with follower sprigs TA-LUFT.

Table 2. Packing types with application ranges.

Packing	Nominal pressure PN / CL	Temperature [°C]
PTFE - V	PN10 - 40 CL150; CL300	-46...+200
PTFE + Graphite		
PTFE - V / TA-LUFT		+200...+250 (+200...+450)*
Graphite		
Graphite / TA-LUFT		

\* - drive retracted from valve (extended yoke)

Table 3...7. Allowable working overpressure for materials at proper temperatures.

PN/CL	Standard	Temperature [°C]							
		-10...50	100	150	200	250	300	350	400
Dopuszczalne ciśnienie robocze [bar]									
PN10	PN-EN1092-1	10	9,2	8,8	8,3	7,6	6,9	6,4	5,9
PN16		16	14,8	14	13,3	12,1	11	10,2	9,5
CL150	PN-EN1759-1	17,3	15,4	14,6	13,8	12,1	10,2	8,4	6,5
PN25	PN-EN1092-1	25	23,2	22	20,8	19	17,2	16	14,8
PN40		40	37,1	35,2	33,3	30,4	27,6	25,7	23,8
CL300	PN-EN1759-1	45,3	40,1	38,1	36	32,9	29,8	27,8	25,7

PN/CL	Standard	Temperature [°C]									
		-10...50	100	150	200	250	300	350	400	425	450
Allowable working pressure [bar]											
PN10	PN-EN 1092-1	10	10	9	8,4	7,9	7,4	7,1	6,8	-	6,7
PN16		16	16	14,5	13,4	12,7	11,8	11,4	10,9	-	10,7
CL150	PN-EN 1759-1	17,9	16,3	14,9	13,5	12,1	10,2	8,4	6,5	5,6	4,7
PN25	PN-EN 1092-1	25	25	22,7	21	19,8	18,5	17,8	17,1	-	16,8
PN40		40	40	36,3	33,7	31,8	29,7	28,5	27,4	-	26,9
CL300	PN-EN 1759-1	46,7	42,5	38,9	35,3	32,9	30,5	28,8	27,6	27,2	26,9

PN/CL	Norma	Temperature [°C]					
		-40	100	150	200	250	300
Allowable working pressure [bar]							
PN10		6	6	3,8	3,6	3,48	3,4
PN16		16	16	10,1	9,6	9,28	9,07
PN25		25	25	15,8	15	14,5	14,2
PN40		40	28	28	27	26	25

PN/CL	Standard	Temperature [°C]								
		-10...50	100	150	200	250	300	350	375	400
Allowable working pressure [bar]										
PN10	EN 1092-1	10	10	9,7	9,4	9	8,3	7,9	7,7	6,7
PN16		16	16	15,6	15,1	14,4	13,4	12,8	12,4	10,8
CL150	PN-EN 1759-1	19,3	17,7	15,8	14	12,1	10,2	8,4	7,4	6,5
PN25	EN 1092-1	25	25	24,4	23,7	22,5	20,9	20	19,4	16,9
PN40		40	40	39,1	37,9	36	33,5	31,9	31,1	27
CL300	PN-EN 1759-1	50	46,4	45,1	43,9	41,8	38,9	36,9	36,6	34,6

PN/CL	Standard	Temperature [°C]										
		-10...50	100	150	200	250	300	350	375	400	425	450
Allowable working pressure [bar]												
PN10	EN 1092-1	8,9	7,8	7,1	6,6	6,1	5,8	5,6	5,5	5,4	5,4	5,3
PN16		14,3	12,5	11,4	10,6	9,8	9,3	9	8,8	8,7	8,6	8,5
CL150	PN-EN 1759-1	18,4	16	14,8	13,6	12	10,2	8,4	7,4	6,5	5,6	4,6
PN25	EN 1092-1	22,3	19,5	17,8	16,5	15,5	14,6	14,1	13,8	13,6	13,5	13,4
PN40		35,6	31,3	28,5	26,4	24,7	23,4	22,6	22,1	21,8	21,6	21,4
CL300	PN-EN 1759-1	48,1	42,3	38,6	35,8	33,5	31,6	30,4	29,6	29,3	29	29

**NOTES:**

- It is allowed to apply carbon steel and acid proof cast steel for temperatures lower than given in Tables 3...7, provided that working pressure is reduced respectively, working temperature impact tests are performed and cast is heat treated. Details are to be consulted with manufacturer.
- Working pressure for intermediate temperature values can be calculated by interpolation.

Table 8. Listing of components with materials

Item	Component	Materials				
1.	Body	GP240GH; (1.0619)	WCB	G20Mn5 ; (1.6220)	GX5CrNiMo 19-11-2; (1.4408)	CF8M
2.	Bridge					
3.	Plug	X6CrNiMoTi 17-12-2 (1.4571); X6CrNiMoTi 17-12-2+stellite X2CrNiMoTi 17-12-2 (1.4404); X2CrNiMoTi 17-12-2+stellite				
4a.	Metallic seat	X6CrNiMoTi 17-12-2 (1.4571); X6CrNiMoTi 17-12-2+stellite X2CrNiMoTi 17-12-2 (1.4404); X2CrNiMoTi 17-12-2+stellite				
4b.	Soft seat	X6CrNiMoTi 17-12-2+PTFE; X2CrNiMoTi 17-12-2+PTFE				
5.	Screw plug	X6CrNiMoTi 17-12-2 (1.4571)				
6.	Shaft	X6CrNiMoTi 17-12-2 (1.4571)				
7.	Guiding sleeve	X6CrNiMoTi 17-12-2 (1.4571)+CrN				
8.	Shaft sealing	X6CrNiMoTi 17-12-2+PTFE				
9.	Packing kit	PTFE-V; PTFE+graphite; GRAPHITE				
10a ,10b	Sealing ring	FKM				
11.	Sweep ring	VMQ				
12.	Disk spring	12R10 (SANDVIK)				
13.	Spacer sleeve	X6CrNiMoTi 17-12-2 (1.4571)				
14.	Lubricating sleeve	X6CrNiMoTi 17-12-2 (1.4571)				
15.	Follower sleeve	X6CrNiMoTi 17-12-2 (1.4571)				
16.	Pressing lever	X6CrNiMoTi 17-12-2 (1.4571) ;GX5CrNiMo 19-11-2 (1.4408)				
17.	Cylindrical pin	X6CrNiMoTi 17-12-2 (1.4571)				
18.	Conical pin	X6CrNiMoTi 17-12-2 (1.4571)				
19.	Stud bolt	8.8			A4-70	
20.	Nut	8			A4-70	
Material relevant standard						
Material		Standard				
GP240GH (1.0619)		PN-EN 10213-2				
WCB		ASTM A 216				
GX5CrNiMo19-11-2 (1.4408)		PN-EN 10213-4				
CF8M		ASTM A 351				
X6CrNiMoTi 17-12-2 (1.4571)		PN-EN 10088				
X2CrNiMoTi 17-12-2 (1.4404)		PN-EN 10088				
NOTES						
- Spare part						

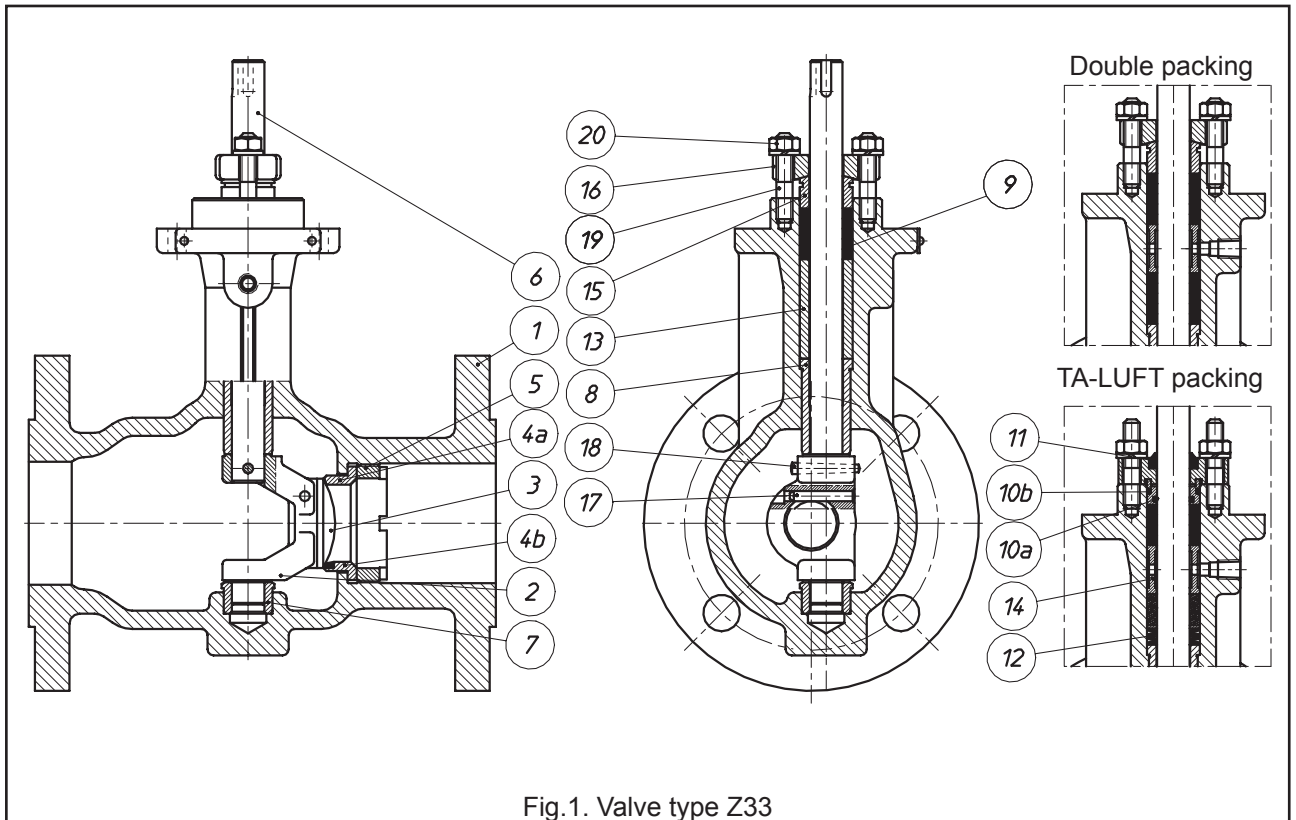

Fig.1. Valve type Z33

## K<sub>v</sub> FLOW RATIOS AND PRESSURE DROPS Δp

Table 9. Metallic seat (leakage class IV); reverse action actuator (air-to-open)

Actuator type						R99-1-R [120 cm <sup>2</sup> ]		R99-2-R [240 cm <sup>2</sup> ]		R99-3-R [780 cm <sup>2</sup> ]	
Spring range [kPa]						100-200	160-320	80-160	160-320	100-200	160-320
DN	K <sub>v<sub>s</sub></sub> 100%	K <sub>v<sub>s</sub></sub> 75%	K <sub>v<sub>s</sub></sub> 45%	K <sub>v<sub>s</sub></sub> ** 120%	Seat dia. [mm]	Maximum pressure drop [bar]					
25	15	11	7	18	18	50*	-	-	-	-	-
25	6	5	3	7	12	50*	-	-	-	-	-
40	40	30	18	48	28,5	50*	-	-	-	-	-
40	16	12	7	19	20	50*	-	-	-	-	-
50	60	45	27	72	38	50*	-	-	-	-	-
50	24	18	11	29	26	50*	-	-	-	-	-
80	150	113	68	180	58	11	32	50*	50*	-	-
80	60	45	27	72	38	33	50*	50*	50*	-	-
100	240	180	108	288	72	2	13	27	50*	-	-
100	96	72	43	115	48	11	36	50*	50*	-	-
150	500	375	225	600	110	-	-	9	23	50*	50*
150	200	150	90	240	72	-	-	25	50*	50*	50*
200	800	600	360	960	136	-	-	-	13	44	50*
200	320	240	144	384	88	-	-	-	37	50*	50*
250	1250	938	563	1500	170	-	-	-	5	20	45
250	500	375	225	600	110	-	-	-	17	50*	50*
300	1800	1350	810	2160	200	-	-	-	2	12	28
300	720	540	324	864	126	-	-	-	10	34	50*

Table 10. Soft seat (leakage class VI); reverse action actuator (air-to-open)

Actuator type						R99-1-R [120 cm <sup>2</sup> ]		R99-2-R [240 cm <sup>2</sup> ]		R99-3-R [780 cm <sup>2</sup> ]	
Spring range [kPa]						100-200	160-320	80-160	160-320	100-200	160-320
DN	K <sub>v<sub>s</sub></sub> 100%	K <sub>v<sub>s</sub></sub> 75%	K <sub>v<sub>s</sub></sub> 45%	K <sub>v<sub>s</sub></sub> ** 120%	Seat dia. [mm]	Maximum pressure drop [bar]					
25	15	11	7	18	18	50*	-	-	-	-	-
25	6	5	3	7	12	50*	-	-	-	-	-
40	40	30	18	48	28,5	50*	-	-	-	-	-
40	16	12	7	19	20	50*	-	-	-	-	-
50	60	45	27	72	38	50*	-	-	-	-	-
50	24	18	11	29	26	50*	-	-	-	-	-
80	150	113	68	180	58	14	35	50*	50*	-	-
80	60	45	27	72	38	38	50*	50*	50*	-	-
100	240	180	108	288	72	5	16	30	50*	-	-
100	96	72	43	115	48	15	40	50*	50*	-	-
150	500	375	225	600	110	-	-	10	25	50*	50*
150	200	150	90	240	72	-	-	28	50*	50*	50*
200	800	600	360	960	136	-	-	-	15	38	50*
200	320	240	144	384	88	-	-	-	39	50*	50*
250	1250	938	563	1500	170	-	-	-	6	18	39
250	500	375	225	600	110	-	-	-	19	48	50*
300	1800	1350	810	2160	200	-	-	-	3	11	25
300	720	540	324	864	126	-	-	-	11	30	50*

\* - Do not exceed nominal pressure

\*\* - For 120% setting it is recommended that listed pressure drops are reduced

In Tables 9...10, theoretical acceptable pressure drops are included. Actual pressure drops with consideration of tolerance of spring manufacture and friction of internal parts of the actuator are lower than those given by 20%. Pressure drops chosen that way guarantee internal tightness of closing of the valves. Calculated ratios:

$$F_L=0,854, X_T=0,6, F_D=0,7, xF_Z=0,58$$

Table 11. Metallic seat (leakage class IV); direct action actuator (air-to-close)

Actuator type						P99-1-P [120 cm <sup>2</sup> ]		P99-2-P [240 cm <sup>2</sup> ]		P99-3-P [780 cm <sup>2</sup> ]	
Voltage pressure [kPa]						240	400	240	400	240	400
DN	K <sub>v<sub>s</sub></sub> 100%	K <sub>v<sub>s</sub></sub> 75%	K <sub>v<sub>s</sub></sub> 45%	K <sub>v<sub>s</sub>**</sub> 120%	Seat dia. [mm]	Maximum pressure drop [bar]					
25	15	11	7	18	18	50*	50*	-	-	-	-
25	6	5	3	7	12	50*	50*	-	-	-	-
40	40	30	18	48	28,5	50*	50*	-	-	-	-
40	16	12	7	19	20	50*	50*	-	-	-	-
50	60	45	27	72	38	50*	50*	-	-	-	-
50	24	18	11	29	26	50*	50*	-	-	-	-
80	150	113	68	180	58	11	50*	50*	50*	-	-
80	60	45	27	72	38	33	50*	50*	50*	-	-
100	240	180	108	288	72	2	24	27	50*	-	-
100	96	72	43	115	48	11	50*	50*	50*	-	-
150	500	375	225	600	110	-	-	9	38	50*	50*
150	200	150	90	240	72	-	-	25	50*	50*	50*
200	800	600	360	960	136	-	-	-	23	44	50*
200	320	240	144	384	88	-	-	-	50*	50*	50*
250	1250	938	563	1500	170	-	-	-	10	20	50*
250	500	375	225	600	110	-	-	-	29	50*	50*
300	1800	1350	810	2160	200	-	-	-	5	12	44
300	720	540	324	864	126	-	-	-	17	34	50*

Table 12. Soft seat (leakage class VI); direct action actuator (air-to-close)

Actuator type						P99-1-P [120 cm <sup>2</sup> ]		P99-2-P [240 cm <sup>2</sup> ]		P99-3-P [780 cm <sup>2</sup> ]	
Voltage pressure [kPa]						240	400	240	400	240	400
DN	K <sub>v<sub>s</sub></sub> 100%	K <sub>v<sub>s</sub></sub> 75%	K <sub>v<sub>s</sub></sub> 45%	K <sub>v<sub>s</sub>**</sub> 120%	Seat dia. [mm]	Maximum pressure drop [bar]					
25	15	11	7	18	18	50*	50*	-	-	-	-
25	6	5	3	7	12	50*	50*	-	-	-	-
40	40	30	18	48	28,5	50*	50*	-	-	-	-
40	16	12	7	19	20	50*	50*	-	-	-	-
50	60	45	27	72	38	50*	50*	-	-	-	-
50	24	18	11	29	26	50*	50*	-	-	-	-
80	150	113	68	180	58	14	50*	50*	50*	-	-
80	60	45	27	72	38	38	50*	50*	50*	-	-
100	240	180	108	288	72	5	27	30	50*	-	-
100	96	72	43	115	48	15	50*	50*	50*	-	-
150	500	375	225	600	110	-	-	10	40	50*	50*
150	200	150	90	240	72	-	-	28	50*	50*	50*
200	800	600	360	960	136	-	-	-	50*	38	50*
200	320	240	144	384	88	-	-	-	50*	50*	50*
250	1250	938	563	1500	170	-	-	-	11	18	50*
250	500	375	225	600	110	-	-	-	30	48	50*
300	1800	1350	810	2160	200	-	-	-	6	11	50*
300	720	540	324	864	126	-	-	-	19	30	50*

\* - Do not exceed nominal pressure

\*\* - For 120% setting it is recommended that listed pressure drops are reduced

In Tables 11...12, theoretical acceptable pressure drops are included. Actual pressure drops with consideration of tolerance of spring manufacture and friction of internal parts of the actuator are lower than those given by 20%. Pressure drops chosen that way guarantee internal tightness of closing of the valves. Calculated ratios:

$$F_L=0,854, X_1=0,6, F_D=0,7, xF_z=0,58$$

## VALVE DRIVES

Rotary pneumatic valves, diaphragm and spring type P/R - 99, with or without a handwheel - special design to drive Z33 valves.

Table 13. Types of rotary pneumatic actuators .

Size	Diaphragm effective area [cm <sup>2</sup> ]	Spring range [kPa]	Rotation angle of output element (crankshaft)
P/R 99-1	120	100...200, 160...320	25° - 45° - 60° - 90°
P/R 99-2	240	80...160, 160...320	
P/R 99-3	780	100...200, 160...320	

### ACTUATOR CHARACTERISTICS:

- total reversibility of action, allowing change in function from “air-to-close - P” to “air-to-open - R”, with no extra parts,
- ability to mount actuator on valve, in various positions, pivoting with 90° increments,
- option with a handwheel,
- fixed diaphragm effective area, ensuring linear movement to pressure ratio,
- optional NAMUR connections.

### DESIGN AND TECHNICAL SPECIFICATION OF ACTUATOR:

**Body (21)** - among the basic components of actuator, designed to hold and assemble other components; executed in grey or spheroidal iron.

**Yoke (28)** - connects valve to actuator; executed in grey iron or pressed in steel sheets and welded.

**Diaphragm (25) and spring (26) case** - make a pressure chamber and springs case; executed as steel die; welded or cast in spheroidal iron.

**Diaphragm (31)** - executed in acrylic-butadiene rubber (NBR); reinforced with nylon insert.

**Diaphragm plate (24)** - formed in plastic or cast in aluminum alloy.

**Lever (22)** - transmits plane motion of membrane unit to rotary movement of crankshaft; executed in spheroidal cast-iron.

**Crankshaft (23)** - in connection with lever makes an output (driving) element of actuator in the form of rotating pin with key grooves; cast in alloy steel and heat processed.

**Spring (29)** - executed in construction spring steel; 2 springs for range 160 - 320 kPa.

**Bearing pin (27)** - connects lever and crankshaft; in special execution (extended) projects from the body and connects actuator to accessories (positioner, limit switches, etc.); executed in alloy steel (stainless steel).

### BASIC TECHNICAL SPECIFICATION OF ACTUATOR:

- maximum supply pressure: 450 kPa
- control air connection: G 1/4"
- connection pipes diameter: Ø6x1 (Ø8x1)
- ambient temperature range: - 40°C ...+ 80°C
- control pressure change tolerance:
  - with no positioner: 4% of nominal range
  - with positioner: 1.5% of nominal range
- hysteresis deviation:
  - with no positioner: 4% of stroke range
  - with positioner: 1% of stroke range
- dead zone:
  - with no positioner: 2% of nominal pressure range
  - with positioner: 1% of nominal pressure range
- optional accessories (on request):
  - handwheel,
  - positioner,
  - air set,
  - three-way solenoid valve,
  - lock-up valve,
  - limit switches,
  - quick exhaust valve.

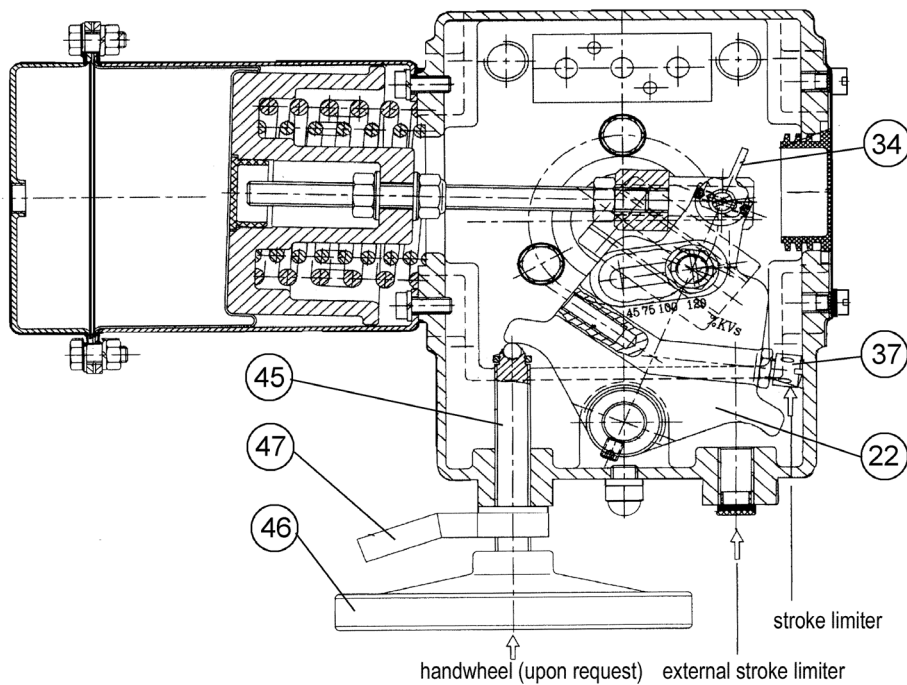
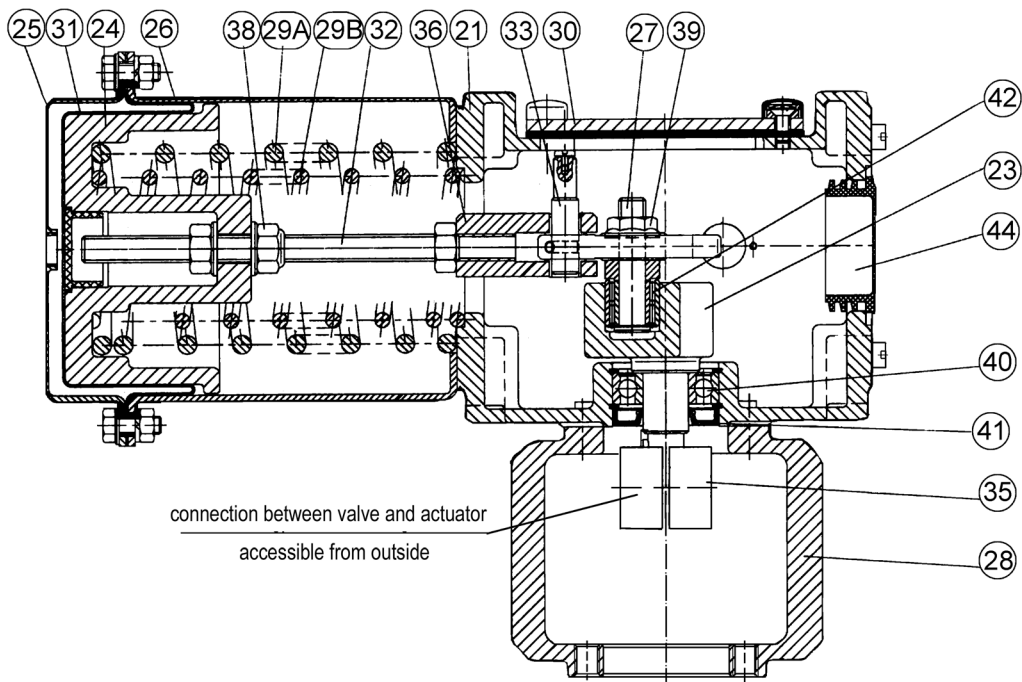

No in fig.	Part
21	Body
22	Lever
23	Crankshaft
24	Diaphragm plate
25	Diaphragm case
26	Spring case
27	Bearing pin
28	Yoke
29	Spring (A+B)
30	Front nameplate
31	Diaphragm
32	Screw
33	Fork pin
34	Stroke indicator
35	Connector
36	Fork
37	Stroke limiter
38	Adjusting nut
39	Securing nut
40	Ball bearing
41	Sealing ring
42	Needle bearing
44	Closure plug
45	Handwheel screw
46	Wheel
47	Counterlever

- Spare parts

Fig. 2. Rotary pneumatic actuator (spring and diaphragm) type P/R-99

**Pneumatic actuators, rotary piston type:**

It is possible to apply rotary piston (spring or springless) actuators by any manufacturer, as required. For detailed technical specifications of actuators and completion methods refer to catalog charts.

**Electric actuators:**

In process installations where no pneumatic actuators can be applied, valves can be driven using electric rotary actuators of various types. For technical specifications refer to separate catalog charts.

**SPECIAL EXECUTIONS:**

Valve executions as per Fig.3.

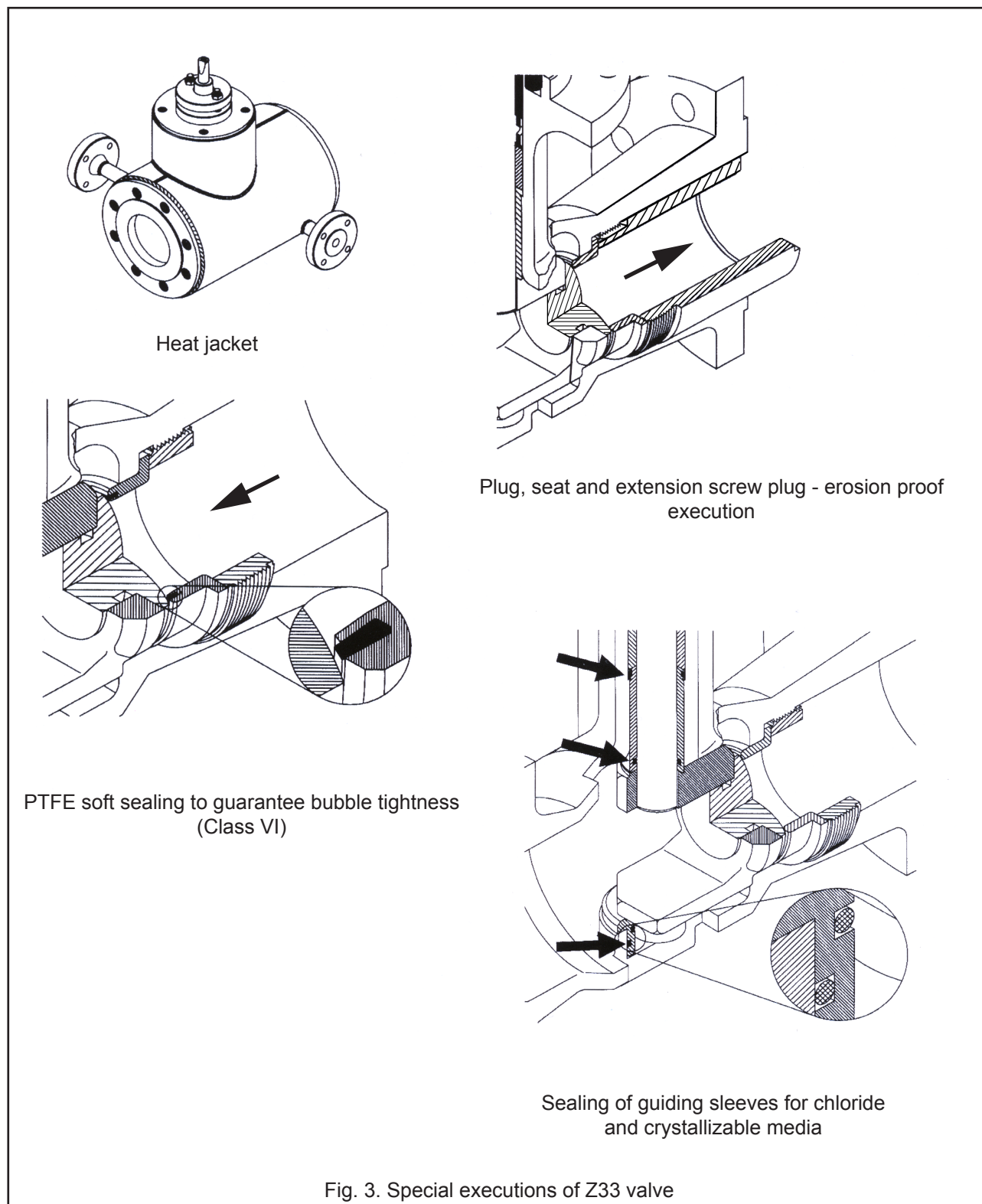
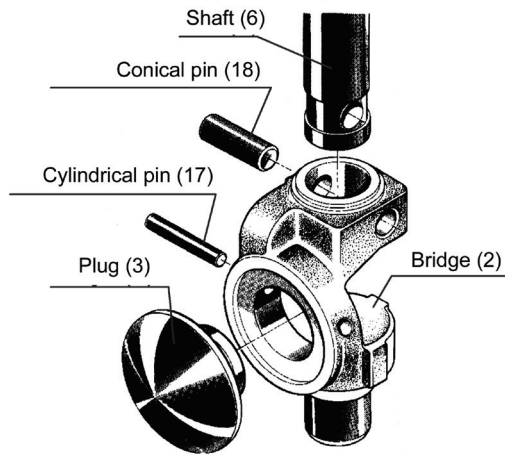

Fig. 3. Special executions of Z33 valve



**OPERATION PRINCIPLE** (transformation of plane motion to rotary motion)



Adjustment of rotation angle of actuator type 99 (patent pending) via system of two levers. **Lever (22)** attached to **diaphragm (24)** plate always turns by 30°, hence stroke, pressure range and positioner feedback lever position do not change. With change in setting of **bearing pin (27)** turn angle of **crankshaft (23)** (and also valve shaft) changes too, within values 25°, 45°, 60° and 90°, which corresponds with changes in flow ratio values to 45%, 75%, 100% and 120% Kvs. In closed position of valve movement of bearing pin to crankshaft guide at the beginning of lever rotation is parallel, hence closed position of valve is maintained. **Connector (35)**, which connects actuator to valve shaft, allows turning of actuator to valve by each 90°, and since it is accessible from outside it eliminates the need for actuator or valve disassembly. Required position (see Fig.5) can be set by manufacturer as per customer's request.

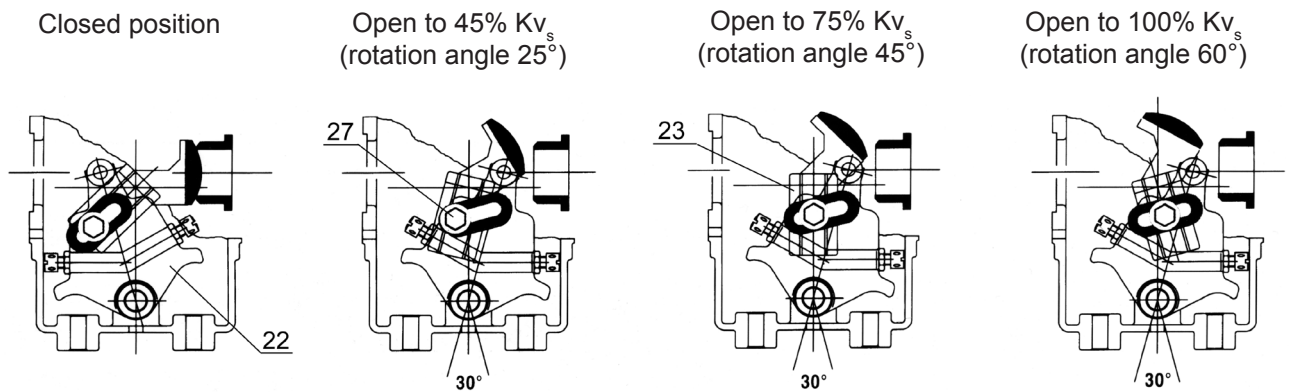

Fig. 4. Bearing pin (27) position on lever (22) regarding crankshaft (23) (valve shaft - Kv<sub>s</sub>) rotation angle.

1. Air-to-open mode (fail-to-close position)

2. Air-to-close mode (fail-to-open)

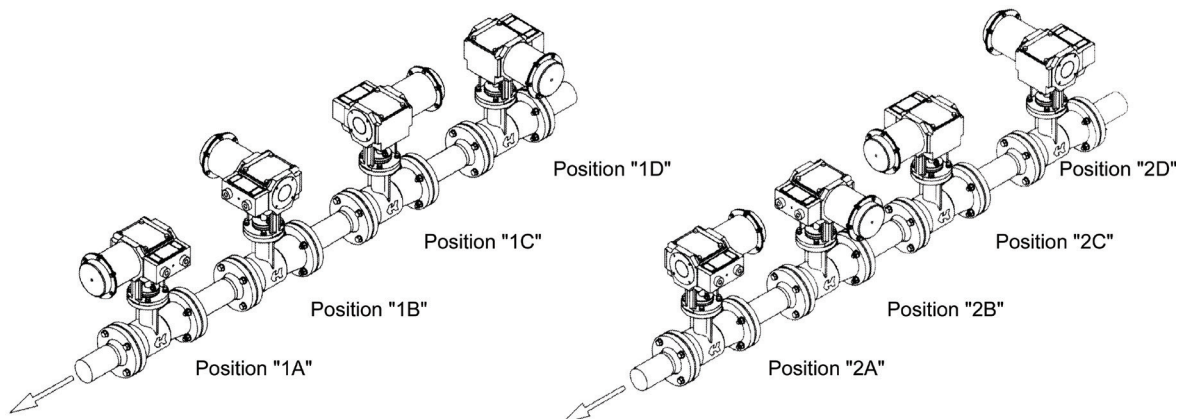

Fig. 5. Possible actuator type P/R-99 positions to valve axis.

## EXTERNAL SIZES, END CONNECTION SIZES; WEIGHTS

Table 14. Valve end connection sizes

DN	End connection as per ISO 5211	E	F	G
25...50	F07	83	16	55
80...100	F12	83	16	85
		116	28	
150	F14	113	28	100
		123	36	
200...300	F16	133	28	130
		120	36	

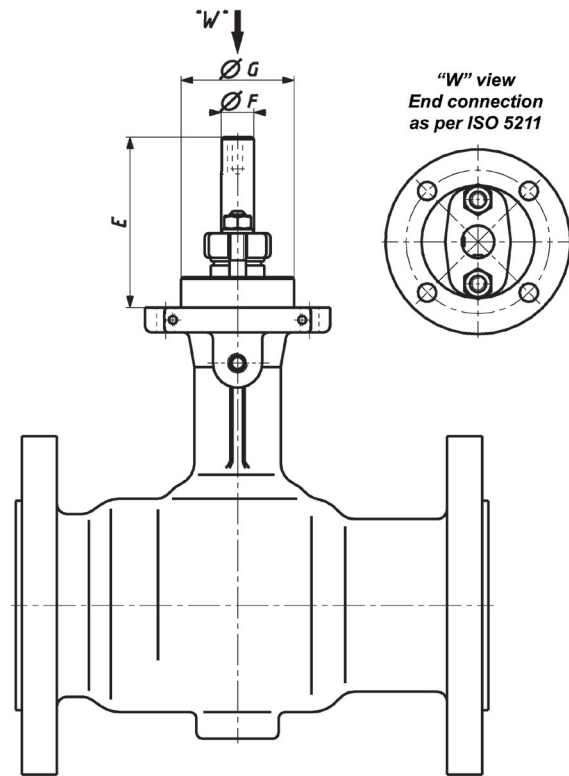

Table 15. Actuator type 99 end connection sizes

Size	End connection as per ISO 5211	L	K	$G^{+0.5}_{-0.3}$	F	S	Weight [kg]
99-1	F07	110	36	55	16	24	18
	F12			85			
99-2	F12	180	60	85	28	60	54
	F14			100			
	F16			130			
99-3	F14	200	60	100	36	71	189
	F16			130			

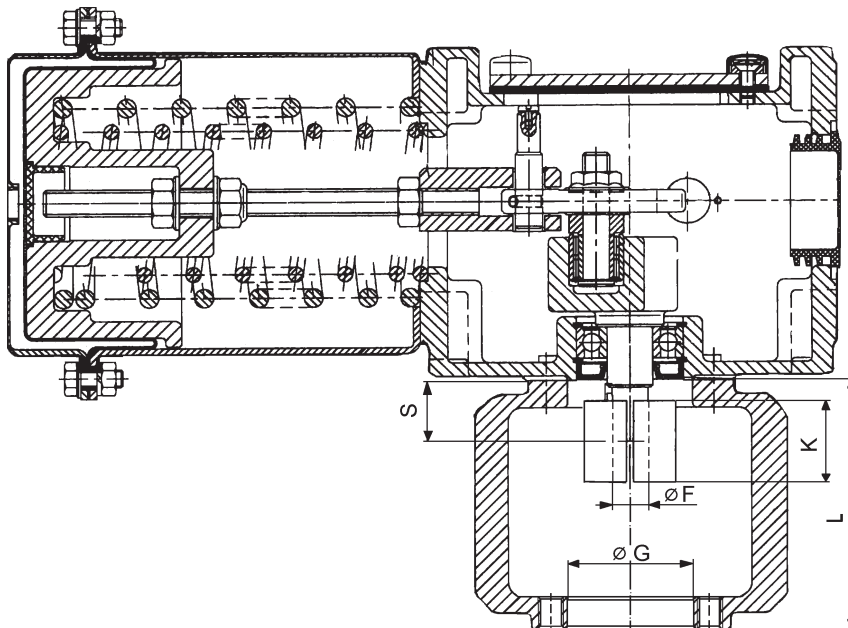
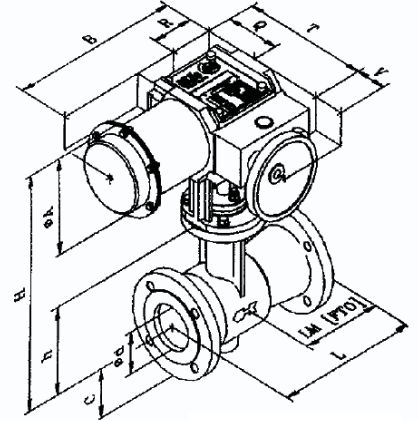
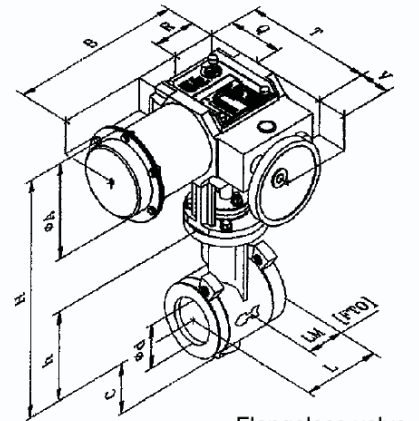

Table 16. Dimensions of valves with actuators type 99

DN	Flanges	Actuator	H [mm]	h [mm]	d [mm]	A [mm]	C [mm]	L [mm]	LM [mm]	B [mm]	R [mm]	Q [mm]	V [mm]	T [mm]	Weight <sup>1)</sup> [kg]
25	PN40	99-1	409	134	37	175	55	160	89	374	92	105	90	234	20
25	CL150	99-1	409	134	37	175	55	184	113	374	92	105	90	234	20
25	CL300	99-1	409	134	37	175	55	197	126	374	92	105	90	234	21
25	Sandw.	99-1	409	134	37	175	55	102	60	374	92	105	90	234	18
40	PN40	99-1	415	140	48	175	64	200	115	374	92	105	90	234	22
40	CL150	99-1	415	140	48	175	64	222	137	374	92	105	90	234	22
40	CL300	99-1	415	140	48	175	64	235	150	374	92	105	90	234	23
40	Sandw.	99-1	415	140	48	175	64	114	64	374	92	105	90	234	20
50	PN40	99-1	420	145	60	175	70	230	123	374	92	105	90	234	23
50	CL150	99-1	420	145	60	175	70	255	135	374	92	105	90	234	23
50	CL300	99-1	420	145	60	175	70	267	141	374	92	105	90	234	25
50	Sandw.	99-1	420	145	60	175	70	124	70	374	92	105	90	234	22
80	PN40	99-1	467	192	88	175	90	310	190	374	92	105	90	234	34
80	PN40	99-2	607	192	88	250	90	310	190	573	135	143	75	348	55
80	CL150	99-1	467	192	88	175	90	298	178	374	92	105	90	234	34
80	CL150	99-2	607	192	88	250	90	298	178	573	135	143	75	348	55
80	CL300	99-1	467	192	88	175	90	318	197	374	92	105	90	234	39
80	CL300	99-2	607	192	88	250	90	318	197	573	135	143	75	348	60
80	Sandw.	99-1	467	192	88	175	90	165	92	374	92	105	90	234	31
80	Sandw.	99-2	607	192	88	250	90	165	92	573	135	143	75	348	52
100	PN40	99-1	477	202	107	175	103	350	215	374	92	105	90	234	55
100	PN40	99-2	617	202	107	250	103	350	215	573	135	143	75	348	76
100	CL150	99-1	477	202	107	175	103	353	223	374	92	105	90	234	55
100	CL150	99-2	617	202	107	250	103	353	223	573	135	143	75	348	76
100	CL300	99-1	477	202	107	175	103	368	234	374	92	105	90	234	65
100	CL300	99-2	617	202	107	250	103	368	234	573	135	143	75	348	86
100	Sandw.	99-1	477	202	107	175	103	194	116	374	92	105	90	234	51
100	Sandw.	99-2	617	202	107	250	103	194	116	573	135	143	75	348	72
150	PN40	99-2	699	284	162	250	195	480	270	573	135	143	75	348	100
150	PN40	99-3	789	284	162	430	195	480	270	925	220	230	70	526	190
150	CL150	99-2	699	284	162	250	195	451	241	573	135	143	75	348	100
150	CL150	99-3	789	284	162	430	195	451	241	925	220	230	70	526	190
150	CL300	99-2	699	284	162	250	195	473	263	573	135	143	75	348	114
150	CL300	99-3	789	284	162	430	195	473	263	925	220	230	70	526	204
150	Sandw.	99-2	699	284	162	250	195	229	140	573	135	143	75	348	82
150	Sandw.	99-3	789	284	162	430	195	229	140	925	220	230	70	526	172
200	PN40	99-2	727	312	204	250	216	600	365	573	135	143	75	348	190
200	PN40	99-3	817	312	204	430	216	600	365	925	220	230	70	526	280
200	CL150	99-2	727	312	204	250	216	543	336,5	573	135	143	75	348	180
200	CL150	99-3	817	312	204	430	216	543	336,5	925	220	230	70	526	270
200	CL300	99-2	727	312	204	250	216	568	349	573	135	143	75	348	210
200	CL300	99-3	817	312	204	430	216	568	349	925	220	230	70	526	300
200	Sandw.	99-2	727	312	204	250	216	243	157	573	135	143	75	348	130
200	Sandw.	99-3	817	312	204	430	216	243	157	925	220	230	70	526	220
250	PN40	99-2	751	336	250	250	250	730	430	573	135	143	75	348	230
250	PN40	99-3	841	336	250	430	250	730	430	925	220	230	70	526	320
250	CL150	99-2	751	336	250	250	250	673	401,5	573	135	143	75	348	200
250	CL150	99-3	841	336	250	430	250	673	401,5	925	220	230	70	526	290
250	CL300	99-2	751	336	250	250	250	708	421	573	135	143	75	348	230
250	CL300	99-3	841	336	250	430	250	708	421	925	220	230	70	526	320
250	Sandw.	99-3	841	336	250	430	250	297	190	925	220	230	70	526	230
300	PN40	99-2	769	338	300	250	258	850	553	573	135	143	75	348	430
300	PN40	99-3	859	338	300	430	258	850	553	925	220	230	70	526	520
300	Sandw.	99-2	769	342	300	250	238	338 <sup>2)</sup>	197,5	573	135	143	75	348	300
300	Sandw.	99-3	859	342	300	430	238	338 <sup>2)</sup>	197,5	925	220	230	70	526	390



Flanged valve  
Actuator P/R-99-1



Flangeless valve  
"Sandwich"  
Actuator P/R-99-1

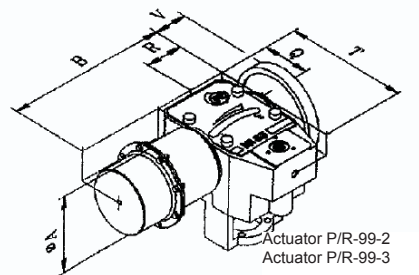

Actuator P/R-99-2  
Actuator P/R-99-3

1) - Valve weight (w/o actuators)  
2) - non-compliant with PN-EN 60534-3-2

## CLASSIFICATION AND MARKING:



### Actuator unit

#### Type:

- pneumatic, rotary, diaphragm-spring, direct action:
- pneumatic, rotary, diaphragm-spring, reverse action:
- pneumatic, rotary, diaphragm-spring, direct action, with a handwheel:
- pneumatic, rotary, diaphragm-spring, reverse action, with a handwheel:
- pneumatic, piston type:
- electric:

P99  
R99  
PN99  
RN99  
PT  
E

### Valve unit

#### Type:

Z33

#### End connection type:

- flanged:
- flangeless (sandwich):

FL  
SD

#### Flow characteristics:

- linear:
- equal percentage:

L  
P

#### Leakage class:

- basic: class IV as per PN-EN 60534-4:
- blister: class VI as per PN-EN 60534-4:

4  
6

### MARKING EXAMPLE:

Control valve type Z33, with actuator type 99, reverse action, with no handwheel, flanged, linear characteristics, basic leakage class:

**R99 - Z33 - FL - L - 4**

Marking is shown on valve nameplate.

Additional information: nominal size (DN), nominal pressure (PN), max working temperature (TS), max working pressure (PS), test pressure (PT), flow ratio (Kvs), plug stroke fluid group (1), serial number / year of manufacture.

### MARKING OF ACTUATOR TYPE 99:

#### Type:

#### Actuator types:

- direct action actuator, with no handwheel:
- direct action actuator, with handwheel:
- reverse action actuator, with no handwheel:
- reverse action actuator, with handwheel:

P  
PN  
R  
RN

#### Diaphragm effective area:

- 120 cm<sup>2</sup>
- 240 cm<sup>2</sup>
- 780 cm<sup>2</sup>

1  
2  
3

#### Spring range:

- 80...160 kPa:
- 160...320 kPa:
- 100...200 kPa:

1  
2  
3

#### End connection as per ISO 5211:

- F07; F12; F14; F16.

### MARKING EXAMPLE:

Pneumatic actuator type 99, diaphragm effective area: 240 cm<sup>2</sup>; simple action, with handwheel, spring range 80...160 kPa; end connection F12:

**PN-99 - 2 - 1 - F12**

### ORDERING

The order should contain all information as per data questionnaire. Full information can be obtained from the Sales and Marketing Department or Technical Department.